



Planning for **integralift**[™]
patient lift

revision 1.0

Table of contents

1.	Planning for Integralift.....	2
2.	Design and room layout.....	3
3.	Technical Planning	6
4.	Personalize Integralift to fit interior design.....	9
5.	Main Components.....	10
6.	Dimensions.....	11
7.	Order Integralift.....	12

1. Planning for **integralift**[™] patient lift

Integra Care Products is a Norwegian design company and the maker of Integralift. Integralift 230 offers a different and more humane way of integrating a patient lift in private homes or in patient rooms.

Integralift is based on the following principles:

- Short, efficient transfer is the preferred way of transfer
- Time is important, the lift is placed where it's needed and always ready
- Appealing positive environments have a big value in homes and workplaces

When planning for Integralift the following procedure is recommended:

- **Design and room layout**
- **Technical planning**
- **Interior design – personalize Integralift**

This planning guide is meant as an introduction to the possibilities that Integralift offers. We want to assist you in your planning.

Please contact Integra or find your nearest dealer and showroom at www.integralift.net. Here you can also find more information about Integralift's functionality and unique features and download manuals.

2. Design and room layout

Integralift is suited for a wide range of different room layouts. When planning for Integralift primary recommended considerations are

- Efficient and ergonomic transfer
 - Place Integralift so that the nurse has easy access to the Integralift cabinet
- Mobility/ maneuverability requirements
 - Sufficient space for two wheelchairs in the lift coverage area
 - Make sure nurses can access a lying patient from both sides of the bed

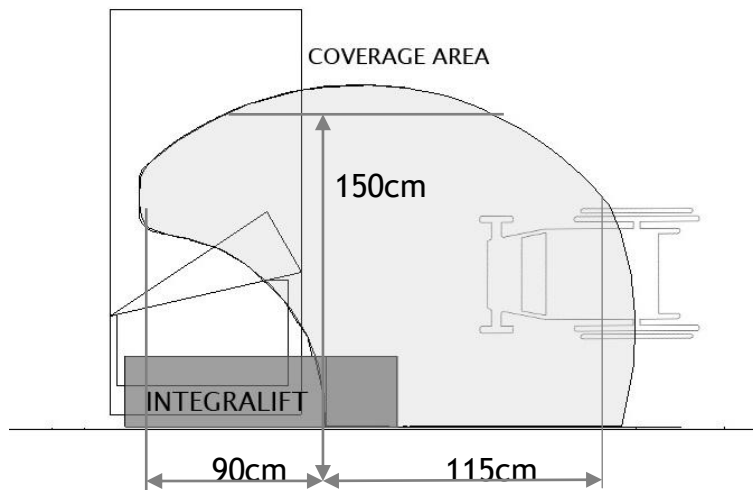

- Nice looking rooms
 - A patient room or bed-room is a place where a lot of time is spent. A decorative room encourages positive attitudes and well being



Patient room

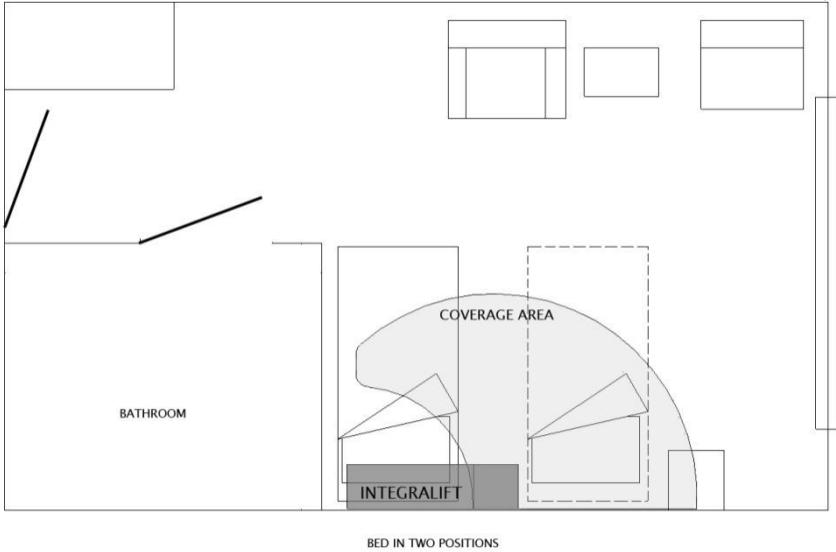

Possible bed positioning: If a patient transfer needs to be done on the other side of the bed, it is no problem to move the bed to the other side of Integralift (position indicated in drawing)

Patient room Twin beds

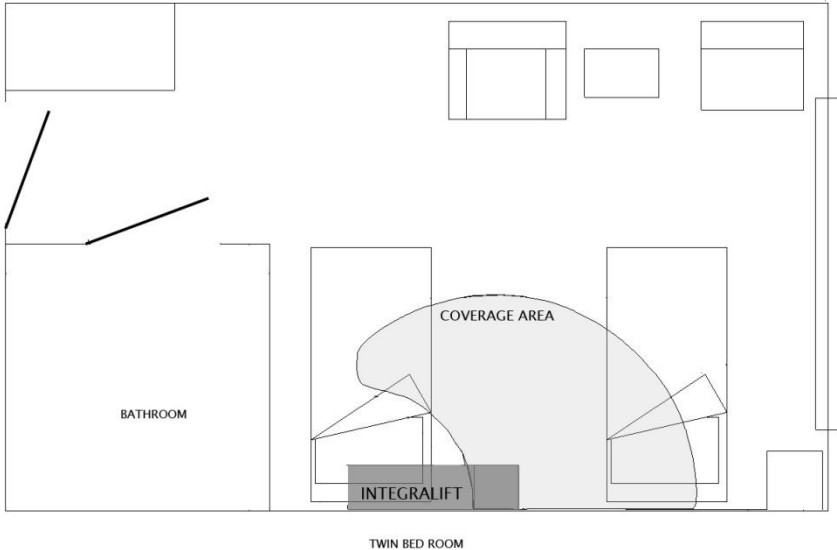

Integralift may be used in rooms with two beds

Private home - Small square room

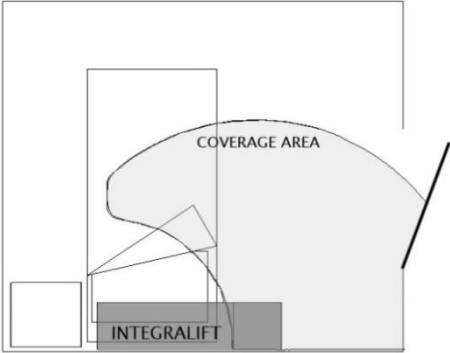

Integralift works well in small rooms where a mobile lift would be difficult to use.

Private home long room, corner placement possible

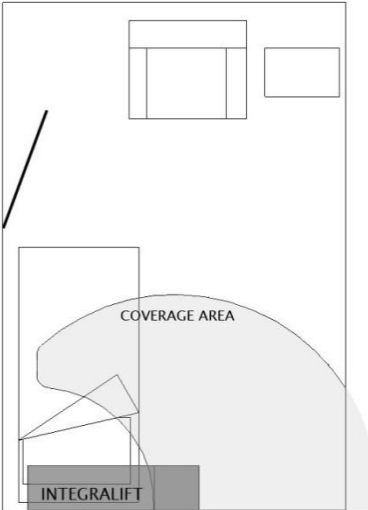

Sometimes users prefer a bed in the corner for efficient space usage.

Corner restrictions

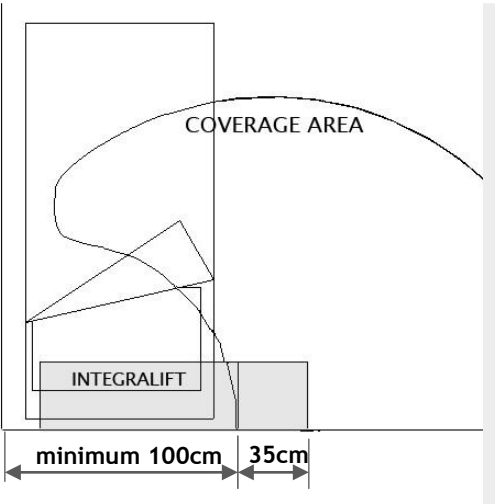

If the bed is placed in a corner remember to plan sufficient space for Integralift.

3. Technical Planning **integralift**[™] patient lift

Integra offers solutions to ease technical planning and Integralift offers new opportunities for room design.

Some Integralift assets:

- Integralift needs only one or two fixing points in the room
- Multiple-height ceilings is no problem
- Pendant lighting no problem
- Possible to integrate electricity and gas in Integralift cabinet
- Fully customizable to match the color of other furniture and walls

Let Integralift dealers assist you in the early on to get the best possible patient handling solution and also a nice looking interior design.

Planning

Correct installation is a critical part when planning for fixed patient lifts, and we recommend planners to contact our certified dealers to ensure that the installation will be executed correctly with the right choice of Integralift structures and the right fasteners.

The methods of installation should be matched with the specific site conditions and all support structures should be verified for applicable loads.

In General

Integralift has a range of different structures that makes it possible to mount Integralift easily in different building materials.

The structures are usually hidden inside the cabinet.

In new builds the structures may also be hidden entirely inside the wall.

The structures may be connected to load bearing structures in different materials:

- Concrete
- Brick and Blocks
- Timber

On the following pages we will present the Integralift structures.

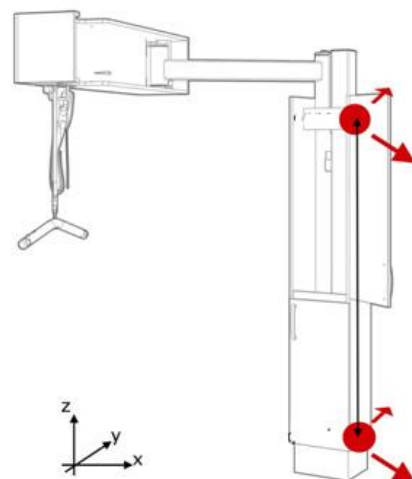

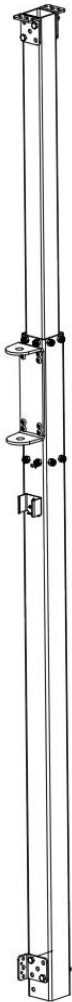

Floor To Ceiling Structure, FC Structure

The FC structure is a highly versatile structure.

It is fixed into the floor (or in the lower part of the wall) and up into the ceiling (or higher part of the wall). The large distance between the fixing points makes FC very stable and possible to mount in concrete but also bricks and wooden structures.

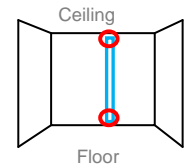

Typical concrete fasteners *2pcs M10x95 Anchor bolts*

Inside Wall Structure, IW Structure

The IW structure is an interesting alternative especially for new builds or rehab where new plasterboards will be mounted. IW is installed before the wall is set up and only two structural “ears” will protrude through the wall.

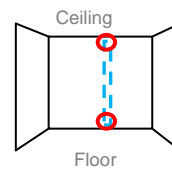

Can be mounted in concrete, brick, blocks or wood.

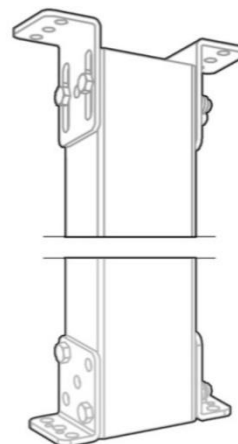
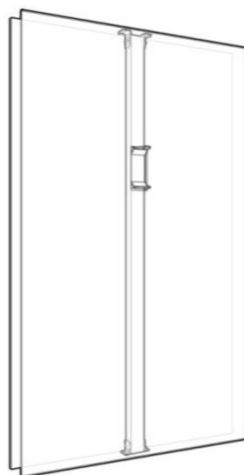
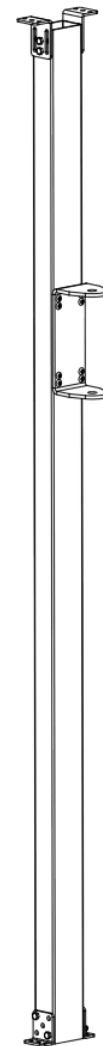

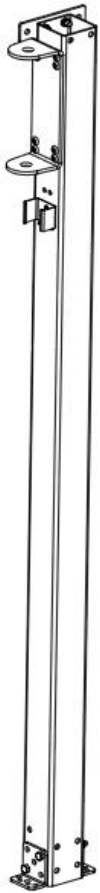

Wall Mount Structure, WM Structure

The WM structure is for connecting to load bearing walls in wood, brick or blocks.

WM is fixed into the lower part of the wall and the higher part of the wall. The WM is hidden inside the Cabinet.

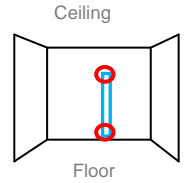

Concrete Wall Structure, CW Structure

The CW structure is very easy to mount on concrete walls. It is bolted to the wall with 8 pcs of M10 Safety anchors or similar.

Typical fasteners:

8pcs Safety Anchor M10 x95

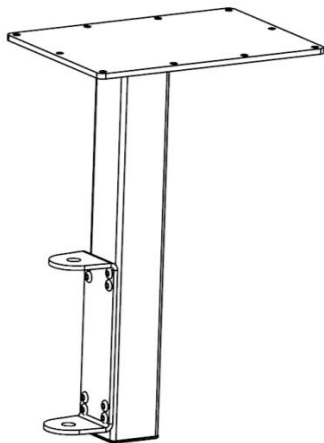
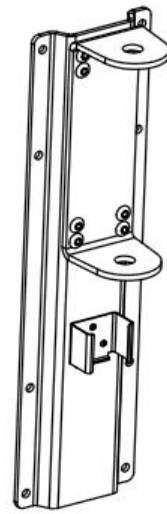
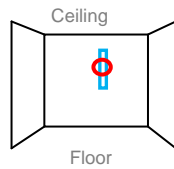

Concrete Ceiling Structure, CC Structure

The Concrete ceiling structure, CC, is a structure that only needs to be fixed in the concrete ceiling.

Typical fasteners: *10pcs Safety Anchor M10 x95*

Remember: This structure has customizable length and is the only structure that comes in left and right versions.

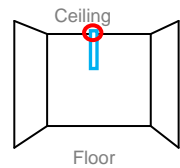

4. Personalize Integralift to fit interior design

In Integra we believe that nice interiors is important for all. We make a great effort in integrating our Patient lift in the interior decoration of a room. This also includes getting a well functioning room. Here Integra and our dealers may help you to find good working solutions.

Standard colours



Jura Beech
Formica Unilin 501

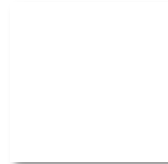

White
Formica Unilin 101



Darkwood-Wenge
Formica Unilin 8964

Customized colours, most colours available

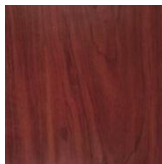

Ex.Redwood
Formica MFC1293

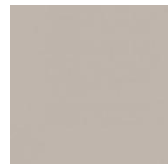

Ex. Folkestone
Formica MFC7927

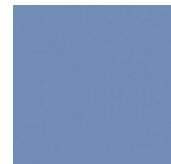

Formica XX

Materials

All Integralift cabinets are made up of quality materials Based on a 16mm core covered with melamine and 2mm PVC Edges

For extra hard usage we offer MDF core covered with high pressure laminates from Formica.



Special Cabinets

Integra can deliver custom cabinets in special dimensions, for example in new builds.

Extras

Downlights: 3 Downlights integrated in the Top cabinet

Matching Furnishing

Together with our dealers we offer a wide range of quality solutions in beds and furnishing that matches Integralift, and makes possible a premium interior design and functionality.



5. Main Components **integralift™** patient lift

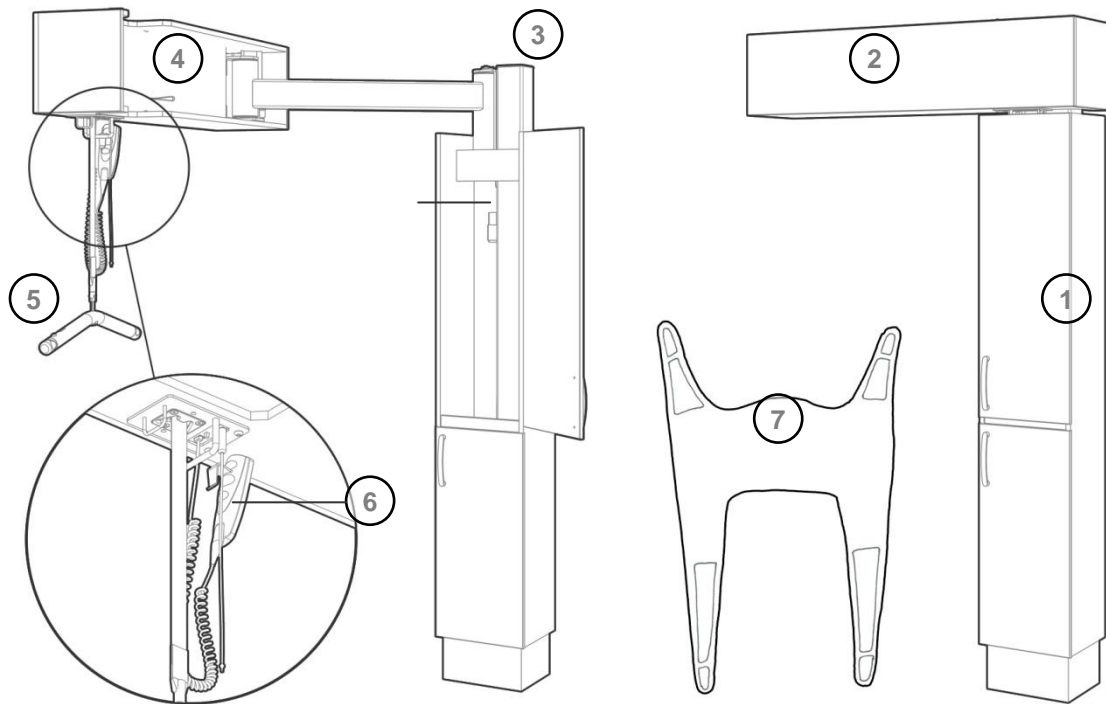

Lifter activated

Lifter inside cabinet

1. Vertical cabinet
2. Top cabinet
3. Vertical structure
4. Lifter
5. Lifting bar
6. Remote control
7. Sling

6. Dimensions **integralift™** patient lift

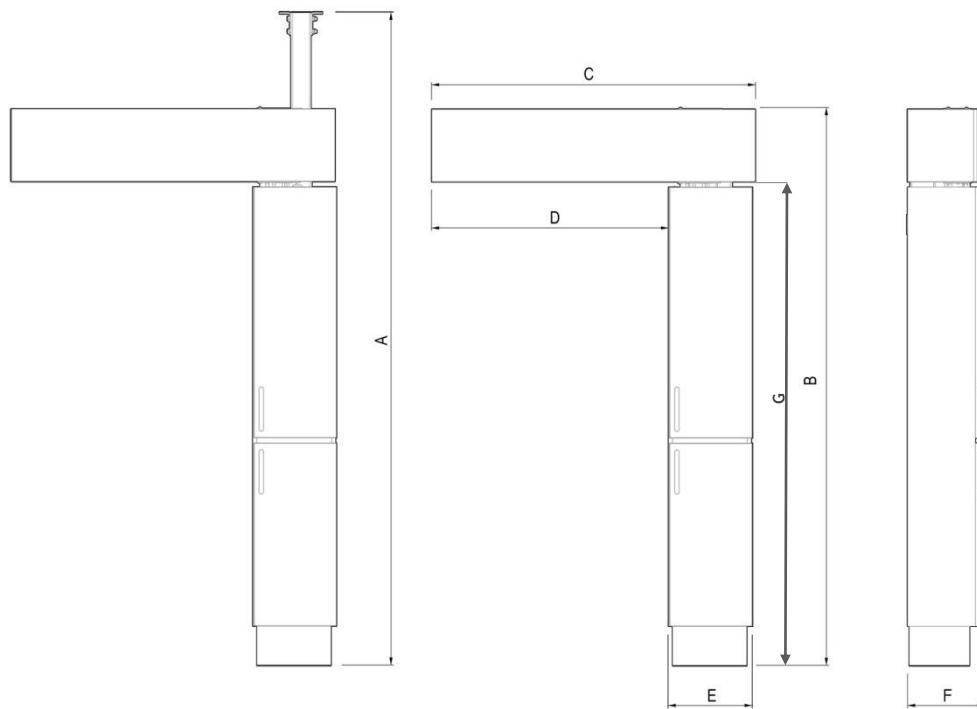

Model	Capacity	A	B	C	D	E	F	G
WM-230	230 kg	220(hidden)	226	124	89	35	30	197
FC-230	230 kg	230-330						
IW-230	230 kg	230-500 (hidden)						
CC-230	230 kg	240-260						
CW-230	230 kg	220(hidden)						

All measurements (A-G) in centimeters.

7. Order **integralift**[™] patient lift

In general we recommend that you contact our dealers before ordering to make sure that you get the right solution.

The most common Integralift models

- Integralift 230 WM -Wall Mount
- Integralift 230 FC -Floor to Ceiling Mount
- Integralift 230 CW -Concrete Wall Mount

On the following Models extra information is needed

- Integralift 230 IW -Inside Wall
 - Order must include height from floor to ceiling
- Integralift 230 CC -Concrete Ceiling
 - Order left/ right versions and include ceiling height
- Integralift 230 CF Concrete Floor
 - A special solution that is fixed only to the floor

Extras

The following extras can be fitted to all Integralift

- Downlights
- Upgrade cabinet to high pressure laminate cabinets
- Custom colour on cabinets

Distributor

Producer:
Integra Care Products AS
Darres gate 22
0175 Oslo - Norway
Tel nr: +47 21 98 26 84
E-mail: post@integralift.net
www.integralift.net